

Assembly Manual for the  $\mu$ SDX „Sandwich“ Design by DL2MAN (Software by PE1NNZ)

The  $\mu$ SDX is a simple but very efficient QRP Multimode Shortwave Transceiver, that is able to transmit and receive SSB, CW, AM and FM. It can be configured for any Shortwave Band by exchanging/modifying RF PCB. Now even as Multiband Rig with switchable Low-Pass Filters.

### **LICENSE:**

The  $\mu$ SDX (Basic Schematic and Software by Guido; PE1NNZ – PCB Design, Layout and Class E Multiband Circuit by Manuel; DL2MAN) is free to use, alter and built

### **FOR NON COMMERCIAL USE ONLY !**

If you alter the PCB Layout or the Source Code, the Source must be mentioned if re-published. The same applies for re-publishing it unaltered. Name the source !

R&D took a lot of our free time, and a lot of our hard earned money. We´re happy to share the results for free with you, but won´t accept, if people make money out of other peoples work.

People interested in commercial use of this Product (or Parts of it), need to ask for permission ([DL2MAN@gmx.de](mailto:DL2MAN@gmx.de) for Hardware, [pe1nnz@amsat.org](mailto:pe1nnz@amsat.org) for Software) .

New Software will be released here: <https://github.com/threeme3/QCX-SSB>

Discussion about this Project here: <https://groups.io/g/ucx/topic/sdxbreakoutboard/75316472?p=,,,20,0,0,0::recentpostdate%2Fsticky,,,20,2,0,75316472>

The DL2MAN „Sandwich“ Design was developed to be able to do changes and add on´s without re-inventing the wheel every time. Kind of a modular concept, which proofed to be working, when you look at the development history. From Monoband „Ghetto“ over Multiband „Ghetto“ to Serial Resonance Class E Multiband with 80 PLUS % Efficiency. The circuit is divided into 3 PCB´s in Size of a Credit Card (85x55mm) so it´s easier to change things in future, and the size was chosen to proof how small it could be built. The  $\mu$ SDX could be even built smaller, but for now I want to stay at that form-factor.

We have

1. Main PCB (with AtMega, PLL, Multiplexer, OpAmp and NAND Gates, Basically the complete RX/TX Core)
2. IO-PCB (With all Knobs, Rotary Encoder, Audio and Mic/Key Jacks)
3. RF PCB with PA and 5 switchable highly efficient, tuned serial resonance, Class E circuits (80m/60m/40m/30m/20m)

IO PCB is Top of the Sandwich, Mainboard is middle and RF PCB is bottom in the final assembly.

PCB's are being connected via standard Jumper Headers and Sockets in 2,54mm/0,1" Spacing.

The Main PCB requires special „stackable“ Headers, that have „male“ and „female“ connector, so we can connect the other PCB's from both sides.

The Main-PCB was re-designed into 4-Layers, so there is a complete GND and VCC Layer between the visible Layers. This is not necessary, but helps in avoiding Ground Loops and reduces Noise in RX of our digital TRX.

The PCB's are mechanically stabilized by Spacers in M3 Threading. Use metal spacers (no Nylon), so they will provide additional GND Connection between PCB's and are very handy to connect for example Oszilloscope GND for measurement.

### **Where to get PCB's ?**

The PCB's can be ordered from <https://jlcpcb.com/> by uploading the zipped Gerber Files from the „PCB-Files“ Folder.

The Process starts with the PCB Dimensions (55x85mm), choosing 2 Layers in case of IO PCB and 4 Layers in case of Main PCB and RF PCB.

Thickness 1,6mm is standard and will do the job.

The Gerber Files do not need to be unpacked. Just upload the Zip File in the next step.

Each zip File is one PCB. The Gerber Files were all tested, and the resulting PCB's from JLCPCB were perfect.

From my own observation, it made most sense to order 10 PCB's each, because this way it was cheapest.

Usually there will be other HAM's around, asking if anybody has a set of spare PCB, so you probably won't end up keeping them.

Otherwise you can just ask in groups.io, if somebody wants to buy your spare PCB's.

Please keep in mind, this is an open source project (other peoples development work, which you can use for free), and I'd appreciate if you just charge your expenses (Non Profit). Keep the HAM Spirit High !

## **Where to get the Parts ?**

I´ve tried to make ordering of the Parts as easy as possible by providing complete „shopping baskets“ at mouser.com  
Mouser has almost every component, most of them in stock and ships virtually anywhere in the world.  
Everything except the toroids can be bought at mouser.

This is the complete Mouser „Shopping Cart“ for uSDX **Mainboard** (including Designators):

<https://www.mouser.com/ProjectManager/ProjectDetail.aspx?AccessID=8690f61c05>

This is the complete Mouser „Shopping Cart“ for uSDX **IO-Board** (including Designators):

<https://www.mouser.com/ProjectManager/ProjectDetail.aspx?AccessID=85157a5769>

This is the complete Mouser „Shopping Cart“ for uSDX **Multi Band serial resonance RF Board** (including Designators):

<https://www.mouser.com/ProjectManager/ProjectDetail.aspx?AccessID=e1ba9350d9>

Those 3 shopping carts contain every part you need to built 1 complete DL2MAN Sandwich.

**EXEPT for the Toroids....**

**Additional to those carts you need 10x Micrometals or Amidon T37-2 (Red) and 1x FT37-43 (Black)**

Please do not order chinese Toroids from ebay or aliexpress, otherwise you will probably see problems with efficiency.

Like the capacitors on the RF Board, the use of High Quality Toroids (Original Micrometals or Amidon) is critical to success !

In America, they can be ordered from <https://www.kitsandparts.com/>

In Europe, they can be ordered from <https://www.reichelt.de/>

In case you have an alternative Source, or the Parts in Stock, it´s easy to remove parts after adding the cart to your order.  
It´s also very easy to order each cart multiple times, if you make group buy or want to built more.

Tips:

- The Display is very expensive at mouser. You can find them cheaper at reichelt.de or on ebay sometimes
- The SMA Connector is also relatively expensive. I´ve used chinese Edge Mount SMA Connectors from ebay. The ones that are supplied with the Si5351 Breakout Boards
- You still need copper enamel wire (I use 0,4mm Diameter for all of my coils)
- The relays come and go, so any IM43 J and G Type will work. I´ve adjusted the Footprint to accept both. (J = SMT J-Leg, G = SMT Gull Wing)
- In worst case you can even use IM42 J or G. Coil code 42 is for 4,5 V Type latching and should still work.
- Gull Wings are easier to Hand solder. Keep that in mind, when you can chose.

Tools required:

- Good Soldering Iron with not too big Tip, but also no needle Tip. My preferred Tip is 2,6mm wide.
- Side cutter
- Stable Tweezers with very small tip
- Flux !
- Good eyes, or alternatively magnification Glass / Microscope
- calm hands ;)

Optional (but not required):

- Stencil for Mainboard and Multiband Board
- Soldering Paste and Reflow Oven

With every new built, I start with Main PCB, as it has the most parts on it.

Some building advice and Project Demonstration can be found in this Video: <https://www.youtube.com/watch?v=qQI9Y6VXzl8&t=3s>

Ordering a stencil (together with PCB) and using solder paste and reflow oven can accelerate built time significantly, but it is not necessary. All the Parts can be soldered by Hand if you just apply the right technique.

An assembly tutorial with tips will be released soon.

Old Manual Text: (Will be reworked soon)

Apply solder paste with stencil, and place all Capacitors (without electrolytic Caps), resistors and Inductances. Place SMT IC's. Solder them in reflow Oven.

Hand Solder electrolytic Caps, Crystals and THT IC's (including 7805), I suggest use of IC Socket at Least for the AT Mega  $\mu$ -Controller. Hand Solder BF170 and Power Jack.

From the Stackable Connector Kit, use the 6Pin and 8Pin Connectors, to create 2x 14 Pin (IO Header 1 and 2).

Male Connectors should be on the side, where the THT IC's are and where the Power Jack is.

Use a file, or Sand Paper, to remove a little bit of the Plastic, where the 6 and 8 Pin Connectors have contact to each other, so they will fit in the 14 Pin Header Holes without force.

Try to solder them in as straight as possible, and try to solder only close to PCB. After placing the AT Mega into Socket, you can Power it up and Program it with an Arduino UNO as ISP.

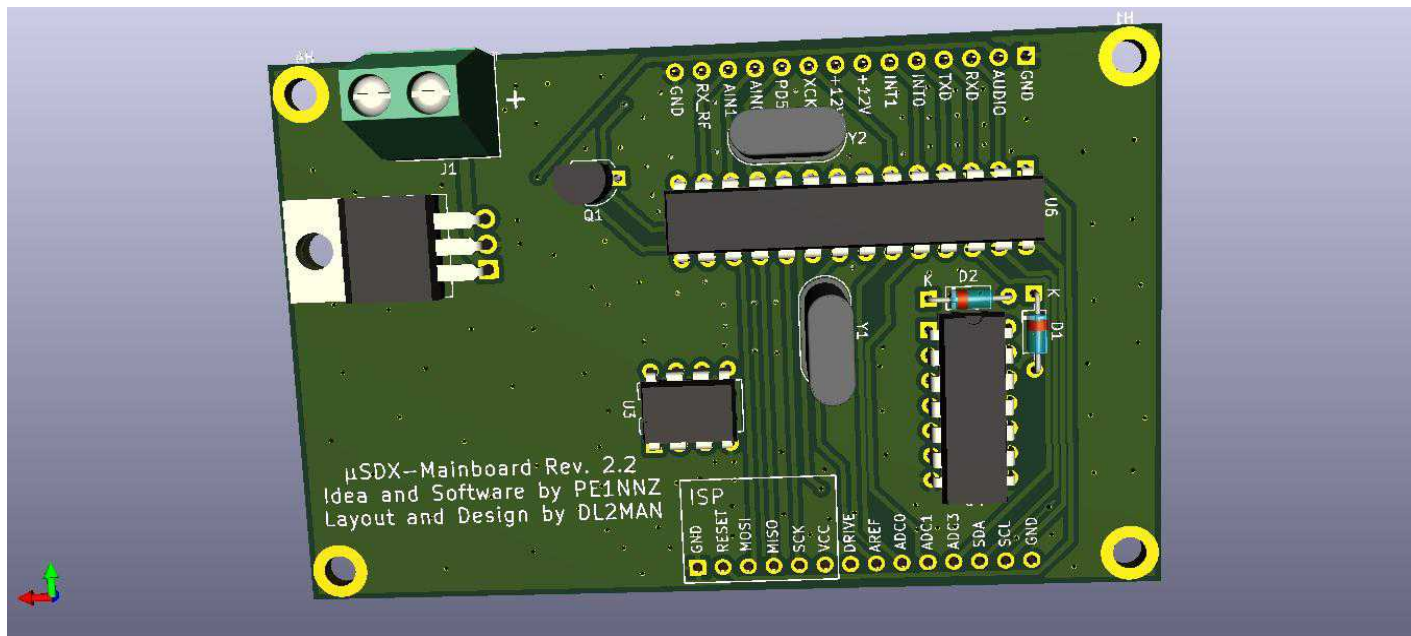

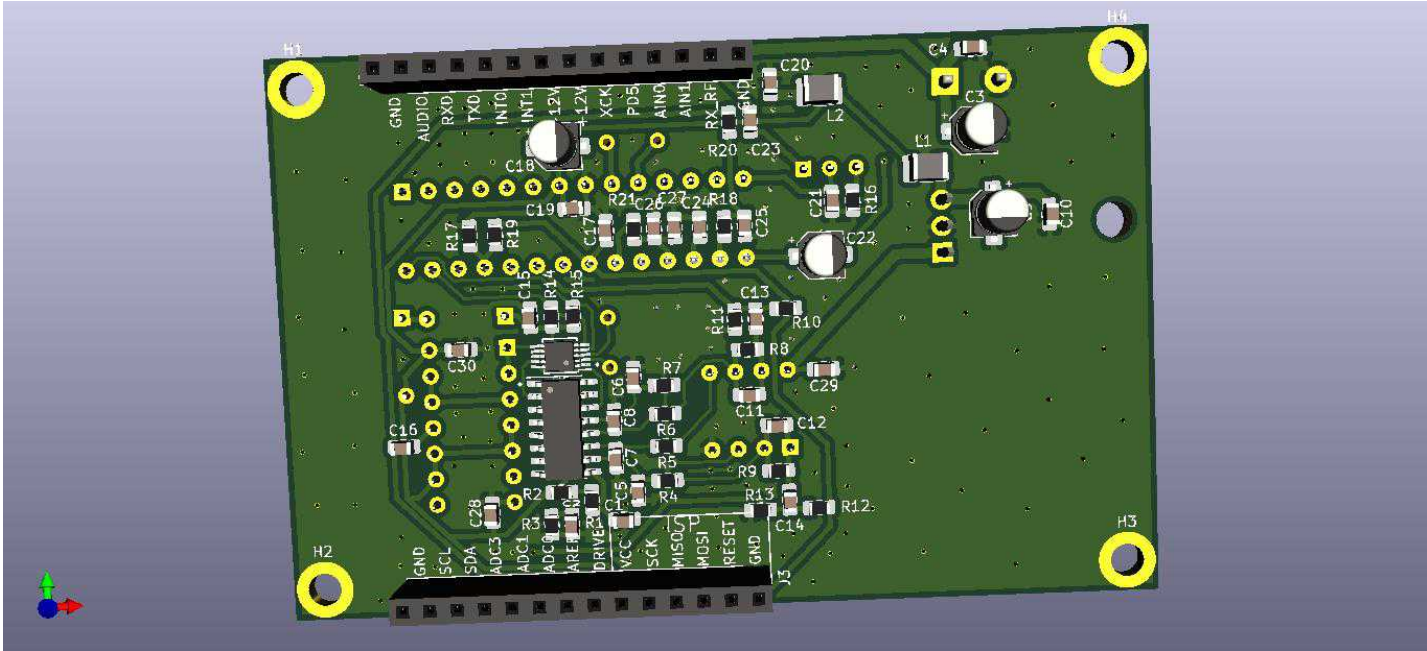

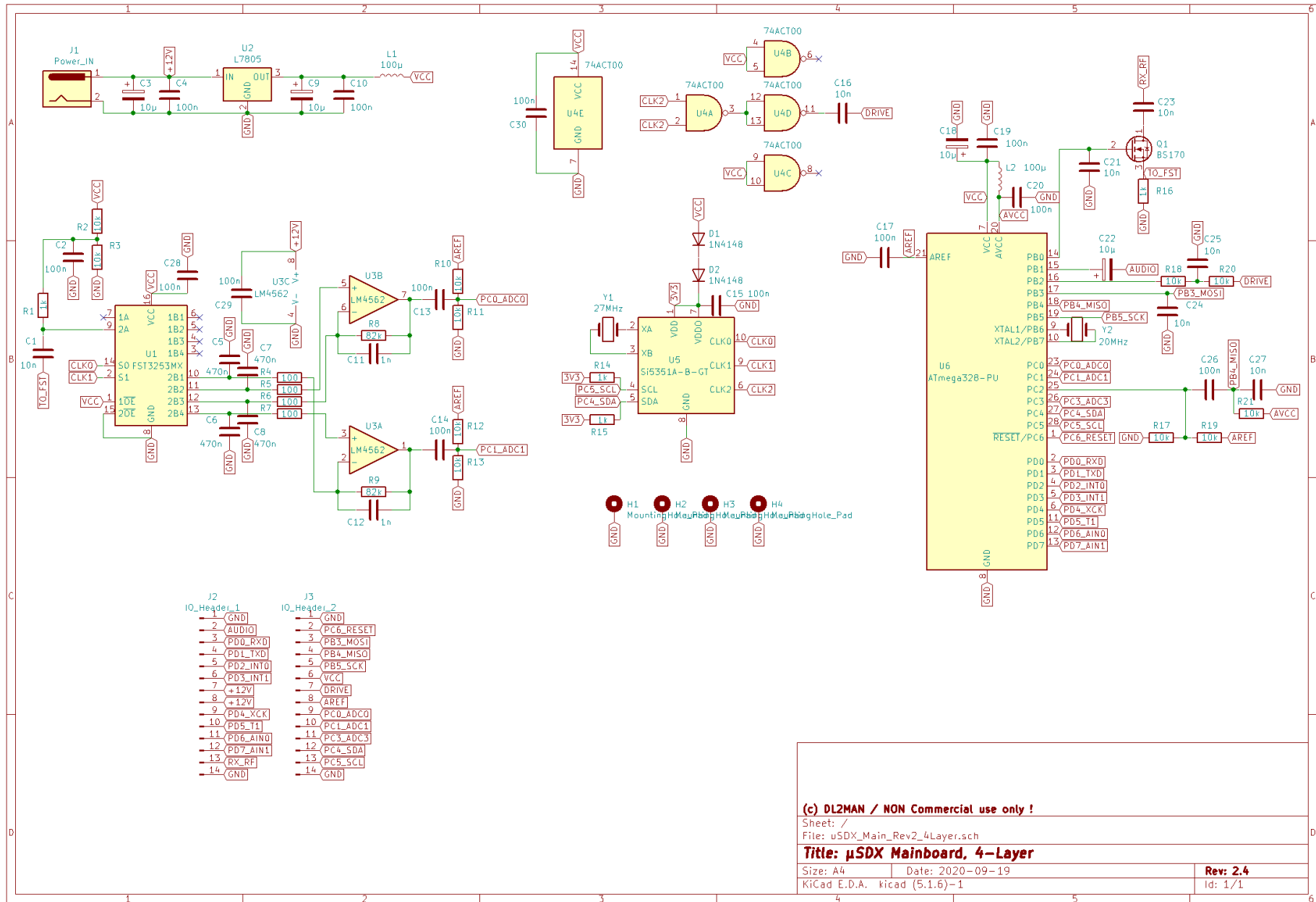

J2	J3
1 IO_Header_1	1 GND
2 GND	2 GND
3 AUDIO	3 PC6_RESET
4 PD0_RXD	4 PB3_MOSI
5 PD1_TXD	5 PB4_MISO
6 PD2_INT0	6 PB5_SCK
7 PD3_INT1	7 VCC
8 +12V	8 DRIVE
9 +12V	9 AREF
10 PD4_XCK	10 PC0_ADCC0
11 PD5_T1	11 PCL_ADC1
12 PD6_AIN0	12 PC3_ADC3
13 PD7_AIN1	13 PC4_SDA
14 RX_RF	14 PC5_SCL
15 GND	15 GND

(c) DL2MAN / NON Commercial use only !  
 Sheet: /  
 File: uSDX\_Main\_Rev2\_4Layer.sch  
**Title: µSDX Mainboard, 4-Layer**  
 Size: A4 Date: 2020-09-19 Rev: 2.4  
 KiCad E.D.A. kicad (5.1.6)-1 Id: 1/1

Mainboard: Component Count:		71	
Ref	Qty	Value	Description
C1, C16, C21, C23, C24, C25, C27,	7	10n	Capacitor SMT 0805 X7R
C2, C4, C10, C13, C14, C15, C17, C19, C20, C26, C28, C29, C30,	13	100n	Capacitor SMT 0805 X7R
C3, C9, C18, C22,	4	10μ	Capacitor electrolytic SMT
C5, C6, C7, C8,	4	470n	Capacitor SMT 0805 X7R
C11, C12,	2	1n	Capacitor SMT 0805 X7R
D1, D2,	2	1N4148	1N4148
H1, H2, H3, H4,	4	MountingHole_Pad	MountingHole_Pad
J1,	1	Power_IN	Terminal Block_Phoenix
J2,	1	IO_Header_1	Cut from Adafruit Accessories 36pin
J3,	1	IO_Header_2	Stacking Header 5 pack
L1, L2,	2	100μ	Fixed Inductor SMT Size 1210
Q1,	1	BS170	BS170
R1, R14, R15, R16,	4	1k	Resistor SMT 0805
R2, R3, R10, R11, R12, R13, R17, R18, R19, R20, R21,	11	10k	Resistor SMT 0805
R4, R5, R6, R7,	4	100	Resistor SMT 0805
R8, R9,	2	82k	Resistor SMT 0805 0,1%
U1,	1	FST3253MX	FST3253 TSSOP-16 Package
U2,	1	L7805	7805 in TO220 Package
U3,	1	LM4562	LM4562 in DIP-8 Package
U4,	1	74ACT00	74ACT00 ins DIP-14 Package
U5,	1	Si5351A-B-GT	Si5351A-B-GT in MSOP-10 Package
U6,	1	ATmega328-PU	Atmega328-PU in DIP-28 Package
Y1,	1	27MHz	Crystal in HC49-US Package
Y2,	1	20MHz	Crystal in HC49-US Package



Continue with IO Board:

This built is actually pretty straight forward. Start with hand soldering the smaller parts (Resistors), Leave out R6 to save another 10mA of RX Current.

This resistor is for LCD Background illumination, but it's not needed if you have green LCD. It can be read without.

Continue with Poti, Mic, Buttons.

Then you need to solder in J1 and J2 (You need to do this before soldering Display, otherwise solder joints cannot be reached anymore).

Then solder in Display and rotary encoder.

The on-Board Mic (MK1) is a standard electret type capsule. It is being disconnected, when a plug is inserted in Key/Mic Jack.

Note: One of the 4 Spacers is below display and cannot be fit with M3 Screw. So this one is only a spacer. The other 3 also aid in mechanical stabilisation and GND Connection.

Note 2: You should bend the metal clamps of the frame on the backside of the LCD a little, to avoid contact with the IO Header.



IO PCB			
SW4	1	Rotary_Encoder_SW	RotaryEncoder_Alps_EC11E-Switch
H3,H4,H2,H1	4	MountingHole_Pad	Spacer 10mm, M3 Threading Male/Female
MK1	1	EMY-9765P	Condenser Microphone
J1	1	IO_Header_1	Use „breakable“ male Pin headers.
J2	1	IO_Header_2	Use „breakable“ male Pin headers.
R1	1	3,3k	Resistor, SMT, 0805
R2,R6	2	1k	Resistor, SMT, 0805 (Leave Out R6 for no Background illumination)
R3	1	10k	Resistor, SMT, 0805
R5	1	270	Resistor, SMT, 0805
SW2	1	Left	Print Push Button_6mm_H5mm
SW3	1	Right	Print Push Button_6mm_H5mm
J3	1	Mic	Jack_3.5mm_with 2x internal Switch (eg LUM 1503-09)
J4	1	Headphones	Jack_3.5mm_with 2x internal Switch (eg LUM 1503-09)
SW1	1	PTT/Key	Print Push Button_6mm_H5mm
J6,J7	1	LCD 162 DIP	LCD Display „162 DIP“ Green
R4	1	27k	Resistor, SMT, 0805
RV1	1	POT 10k	Potentiometer_Piher_PT-6-V_Vertical

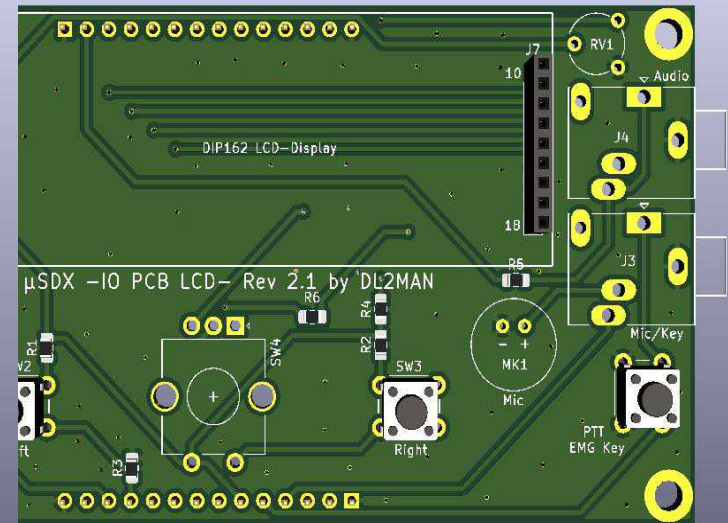
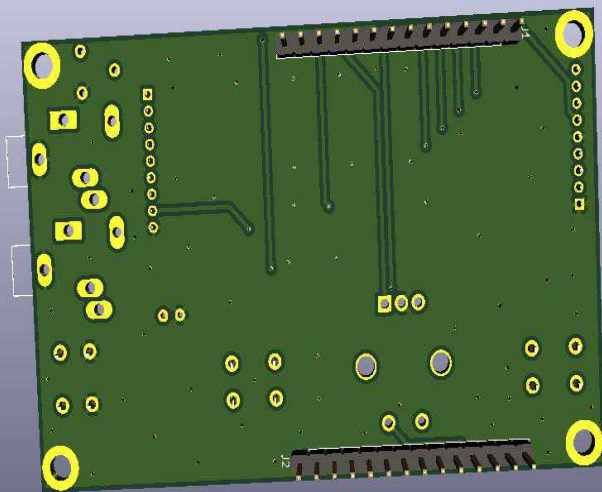

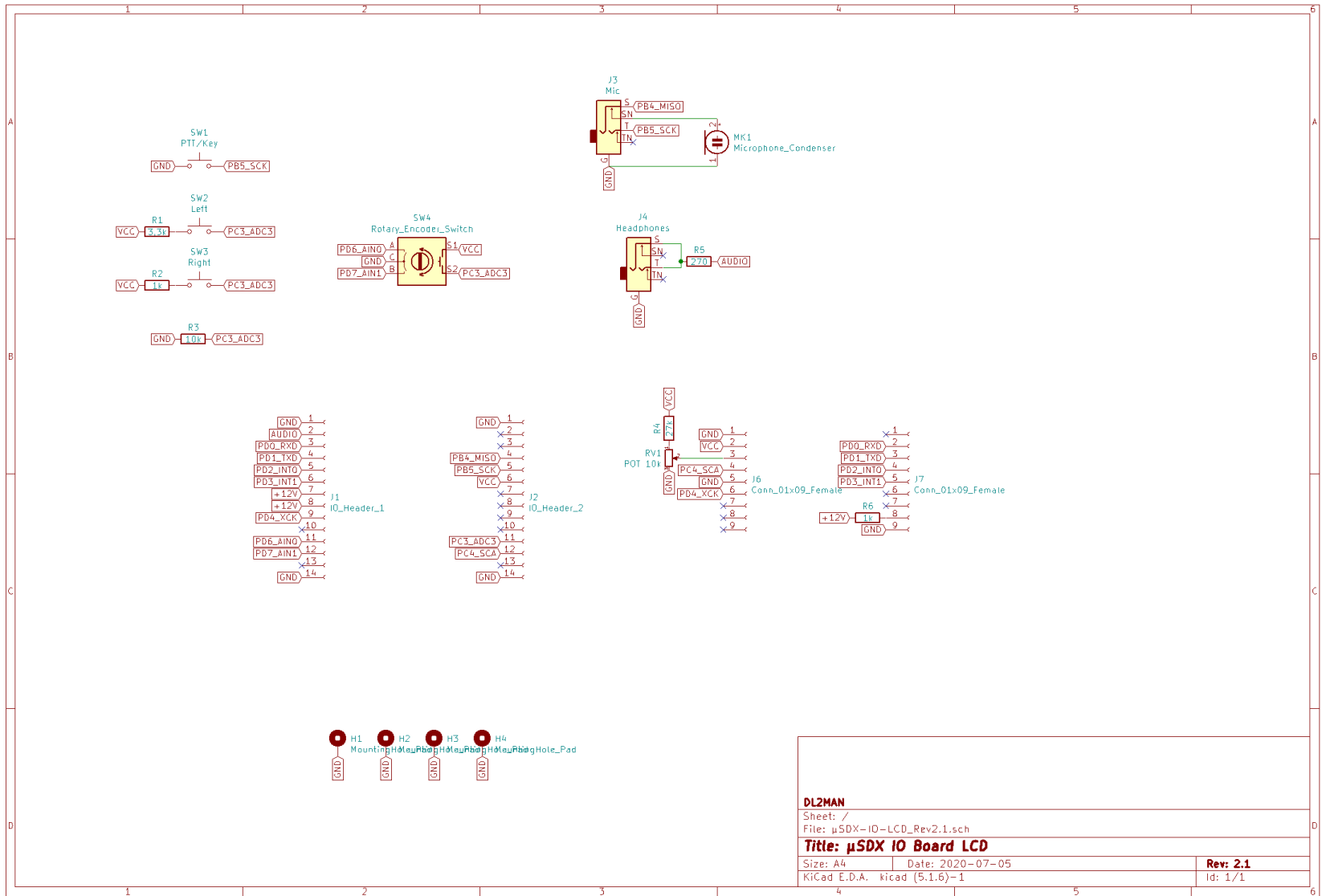

<b>DL2MAN</b>		
Sheet: /		
File: μSDX-IQ-LCD_Rev2.1.sch		
<b>Title: μSDX IO Board LCD</b>		
Size: A4	Date: 2020-07-05	<b>Rev: 2.1</b>
KiCad E.D.A. kicad (5.1.6)-1		
Id: 1/1		

And finally we take care about RF PCB – **NEW serial resonance Multi-Band PCB !**

First place the Capacitors, the Resistor and the GPIO Expander IC on the Board (U1) according to the Schematic and BOM Table below.  
The capacitors on this board need to be 0805 NP0/COG Type, rated for 100V !  
Then continue with the Relays:

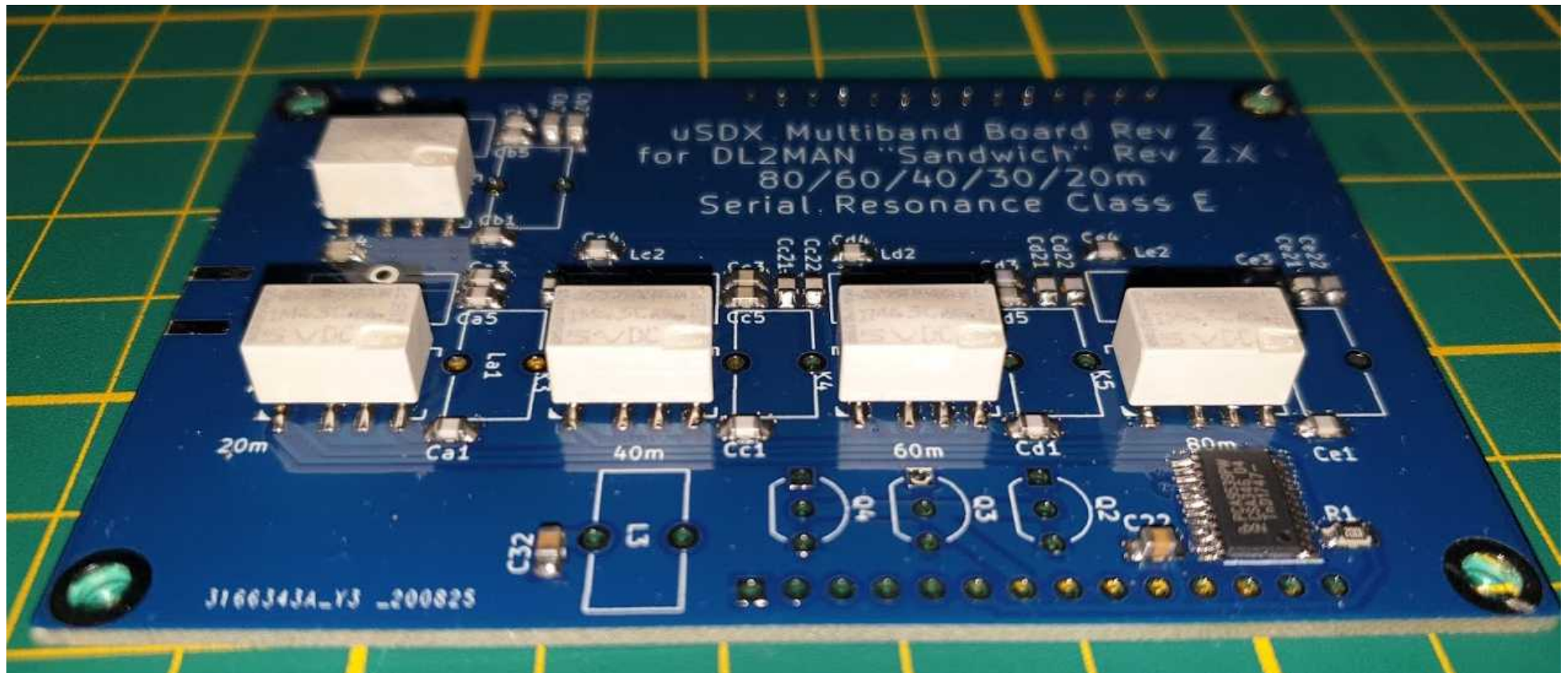



Then select Toroids according to Schematic and wind them with the amount of turns according to Schematic. For Example: 10T/T37-2 means: Use Toroid Core T37-2 (= red one), put on 10 Turns. The given Values were tested with at least 3 Builds and produced always between 4-6W Output (@13,8V) and Efficiency over 80%. The footprint on the PCB almost forces you to divide the windings evenly and I found this gives me much more repeatable results. Remember: When you insert the Copper enamel wire in the core, this is already winding Nr. 1 ! Wind one Toroid Coil after another, scratch off the enamel coating of their ends with a knife, stick the loose ends through PCB and twist them like shown below. Then they won't fall out, and you can solder them after having placed all of them (or a few of them like in my Photo)

This Photo was taken from the first Multiband Version, but the technique is still the same.

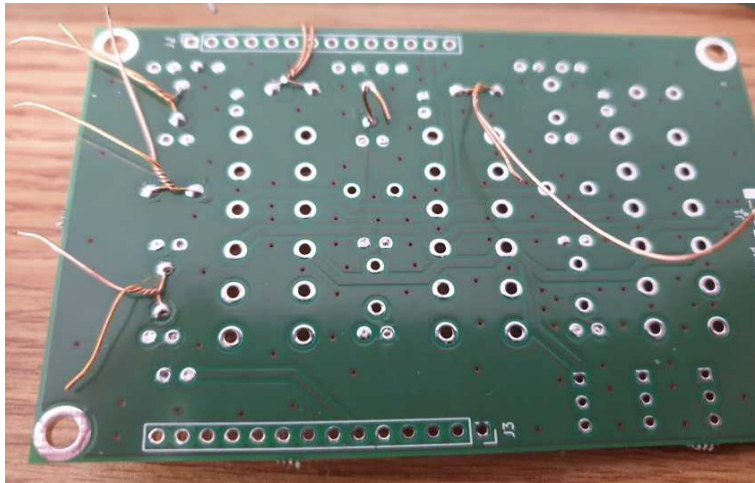

All my coils were wound with 0,4mm Diameter copper enamel wire.

After all Toroids are Placed and soldered, only the BS170's, the SMA Socket and the IO Headers need to be soldered on:

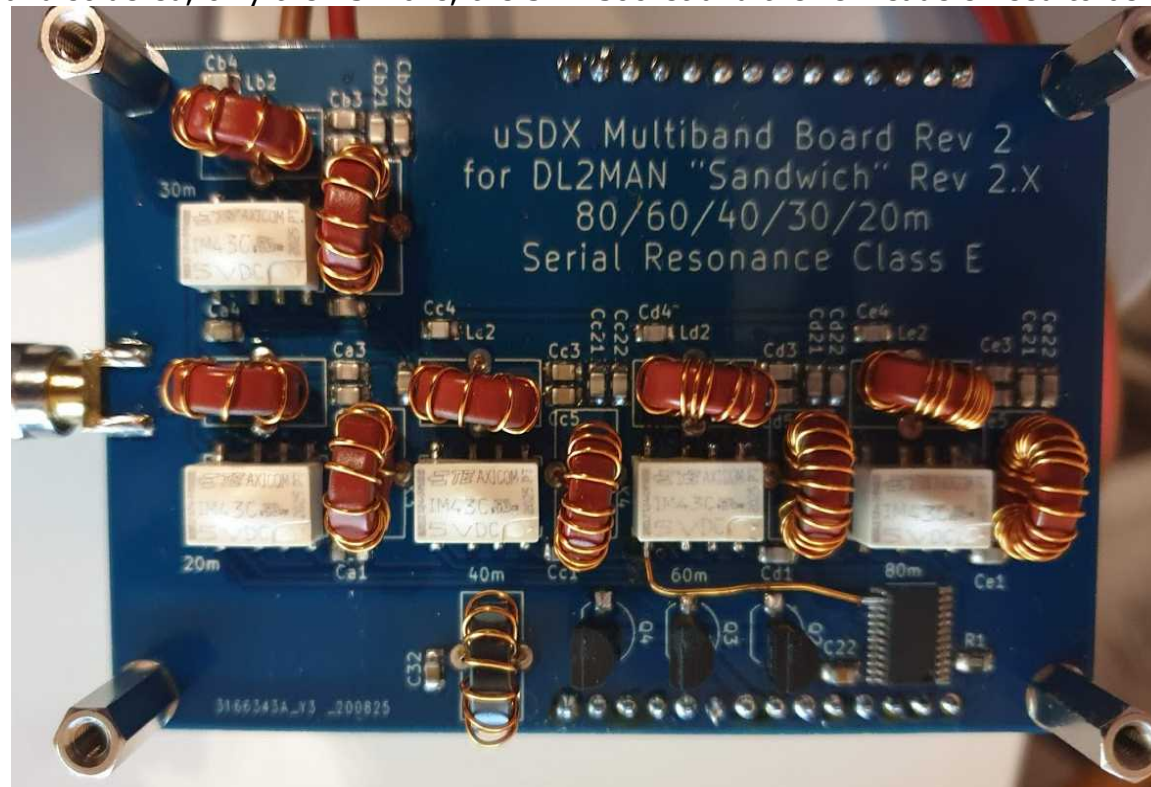

The Software File in „Firmware“ Folder is optimized for use with Relay Switching.

When testing RF Boards, I always measure Input Current and Output Power into Dummy Load.

You can calculate efficiency:

Power In = Voltage in x (Current In while TX – Current while RX)

Efficiency in % = Power Out / Power In x 100

With this built and the above Values in Schematic I get between 82-93% of Efficiency.

You can affect efficiency and output Power by Squeezing windings more together or seperate them more evenly. Usually no more tweaking then that is required.

### Multiband RF Board BOM:

Component Count:	59		
Ref	Qty	Value	Footprint
C1, C2,	2	100n	Capacitor_SMD, Size 0805, X7R Type
Ca1,	1	130p	Capacitor_SMD: Size 0805, NP0/C0G Type, rated for 100V
Ca2, Ca3, Ca5, Cc21, Cc22,	5	470p	Capacitor_SMD: Size 0805, NP0/C0G Type, rated for 100V
Ca4,	1	150p	Capacitor_SMD: Size 0805, NP0/C0G Type, rated for 100V
Cb1,	1	200p	Capacitor_SMD: Size 0805, NP0/C0G Type, rated for 100V
Cb3, Cb5, Ce1,	3	680p	Capacitor_SMD: Size 0805, NP0/C0G Type, rated for 100V
Cb4,	1	220p	Capacitor_SMD: Size 0805, NP0/C0G Type, rated for 100V
Cb21, Cb22,	2	330p	Capacitor_SMD: Size 0805, NP0/C0G Type, rated for 100V
Cc1, Cc4,	2	300p	Capacitor_SMD: Size 0805, NP0/C0G Type, rated for 100V
Cc3, Cc5,	2	1000p	Capacitor_SMD: Size 0805, NP0/C0G Type, rated for 100V
Cd1,	1	430p	Capacitor_SMD: Size 0805, NP0/C0G Type, rated for 100V
Cd3, Cd5,	2	1200p	Capacitor_SMD: Size 0805, NP0/C0G Type, rated for 100V
Cd4,	1	390p	Capacitor_SMD: Size 0805, NP0/C0G Type, rated for 100V
Cd21, Cd22, Ce4,	3	620p	Capacitor_SMD: Size 0805, NP0/C0G Type, rated for 100V
Ce3, Ce5,	2	1800p	Capacitor_SMD: Size 0805, NP0/C0G Type, rated for 100V
Ce21,	1	360p	Capacitor_SMD: Size 0805, NP0/C0G Type, rated for 100V
Ce22,	1	1500p	Capacitor_SMD: Size 0805, NP0/C0G Type, rated for 100V
H1, H2, H3, H4,	4	MountingHole_Pad	MountingHole:MountingHole_3.2mm_M3_DIN965_Pad
J2, J3,	2	Conn_01x14_Female	Connector_PinSocket_2.54mm:PinSocket_1x14_P2.54mm_Vertical
J4,	1	Conn_Coaxial	Connector_Coaxial:SMA_Samtec_SMA-J-P-X-ST-EM1_EdgeMount
K1, K2, K3, K4, K5,	5	IM43JR/GR	Relais:Relay_DPDT_AXICOM_IMSeries_GullWing
L1,	1	12T/FT37-43	12 Turns on FT37-43 Core (Black)
La1, Lc2,	2	10T/T37-2	10 Turns on T37-2 Core (red)
La2,	1	7T/T37-2	7 Turns on T37-2 Core (red)
Lb1, Ld2,	2	12T/T37-2	12 Turns on T37-2 Core (red)
Lb2,	1	8T/T37-2	8 Turns on T37-2 Core (red)
Lc1, Le2,	2	15T/T37-2	15 Turns on T37-2 Core (red)
Ld1,	1	17T/T37-2	17 Turns on T37-2 Core (red)
Le1,	1	21T/T37-2	21 Turns on T37-2 Core (red)
Q2, Q3, Q4,	3	BS170	Package_TO_SOT_THT:TO-92_Inline_Wide
R1,	1	10k	Resistor_SMD, Size 0805
U1,	1	PCA9555	Package_SO:TSSOP-24_4.4x7.8mm_P0.65mm

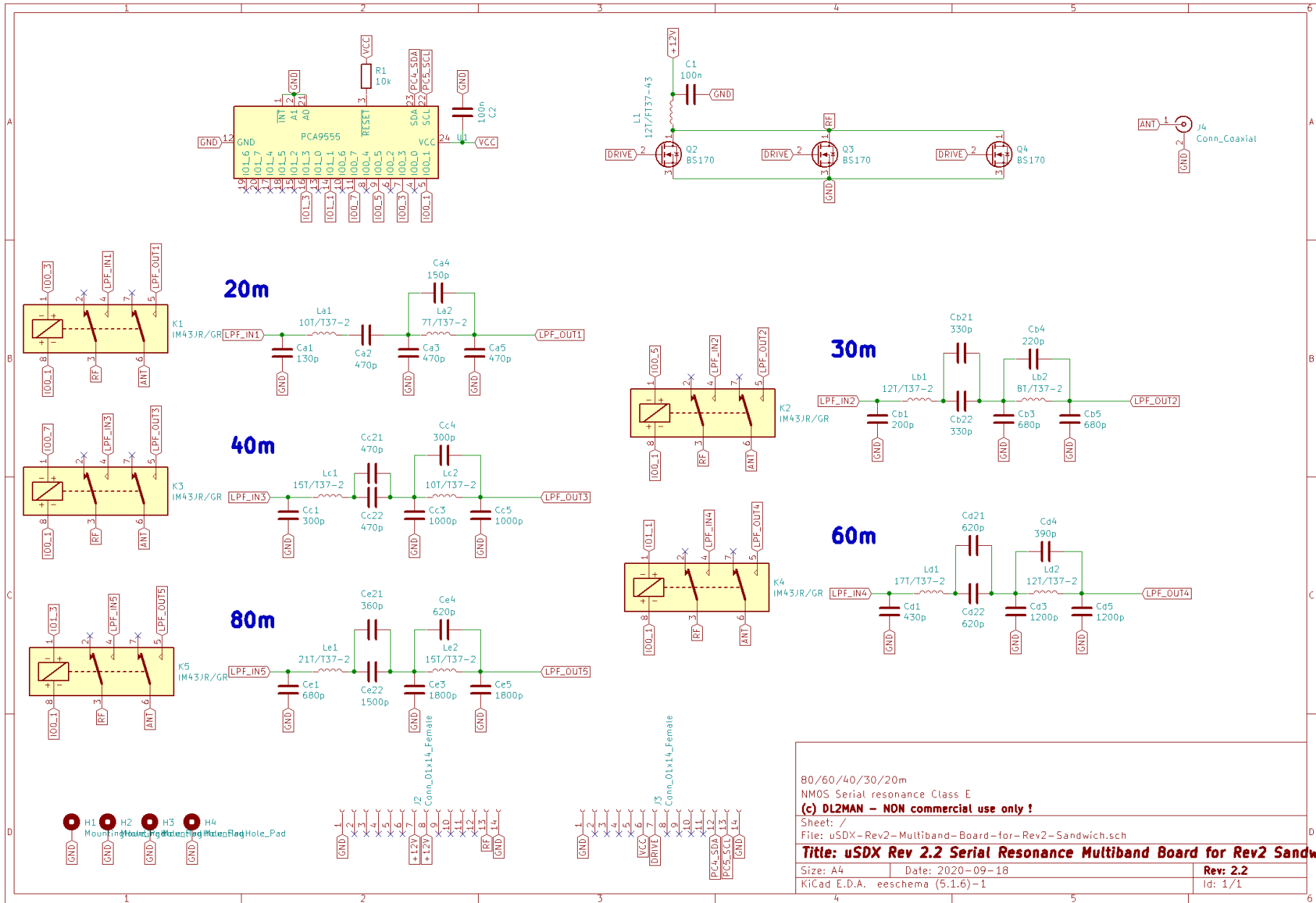

80/60/40/30/20m  
 NMOS Serial resonance Class E  
**(c) DL2MAN - NDN commercial use only !**  
 Sheet: /  
 File: uSDX-Rev2-Multiband-Board-for-Rev2-Sandwich.sch  
**Title: uSDX Rev 2.2 Serial Resonance Multiband Board for Rev2 Sandwich**  
 Size: A4 Date: 2020-09-18 Rev: 2.2  
 KiCad E.D.A. eeschema (5.1.6)-1 Id: 1/1



Final important notes:

- when programming via ISP Interface, you need to insert a 3,5mm Stereo Plug (with nothing connected) into Mic/PTT Jack. Otherwise the internal Diode of the On-Board Microphone will mess with the MISO/SCK Line.
- Be extremely careful, when putting the Sandwich together. It's pretty easy to miss one pin, or even worse: Connect it to the wrong pin.
- Always remove it from Power Supply when Disassembling / Reassembling the boards.
- 

Have fun while building, and please report any bugs and errors while building to [groups.io](https://groups.io)  
or directly to me:  
[DL2MAN@gmx.de](mailto:DL2MAN@gmx.de)